

VANTAGGI / ADVANTAGES / VORTEILE:

- **Binario unico con fori passanti per fissaggio diretto a parete ed a soffitto, senza spessori**
 - Only one track with through holes for direct wall and ceiling mounting, without spacers
- **Innovativa pinza MINI CLAMP con piastra asolata per aggancio rapido e dentino di sicurezza (3)**
 - Innovative MINI clamp with slotted plate for quick coupling and safety anti-release system.
- **Veletta con predisposizione spazzolino (1) e fissaggio tappo di chiusura laterale (2)**
 - Plinth panel with predisposition strip brushes (1) and end cap (2)

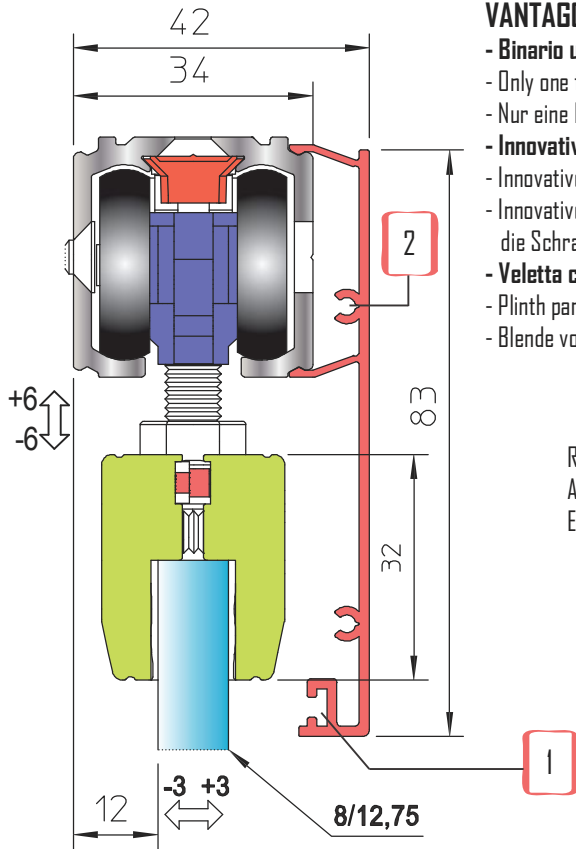

Riscontro regolabile
 Adjustable stop
 Einstellbarer Anschlag

pag. 6  3

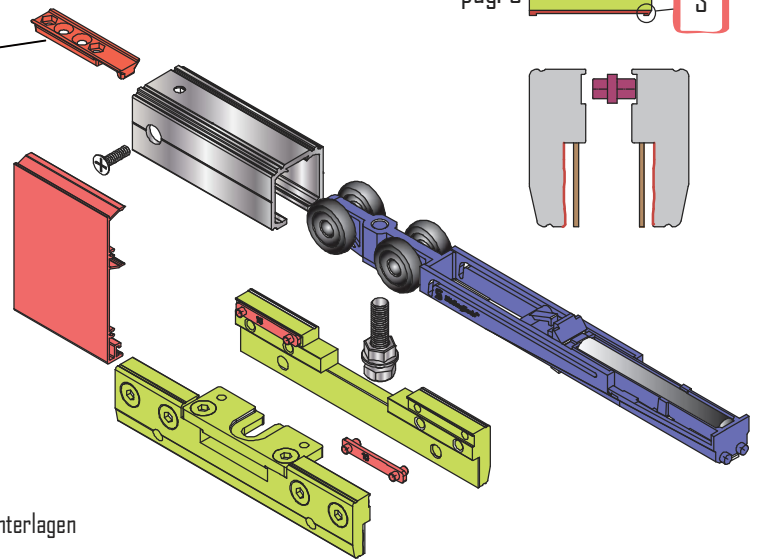

No spessori / No shims / Keine Stärkeunterlagen

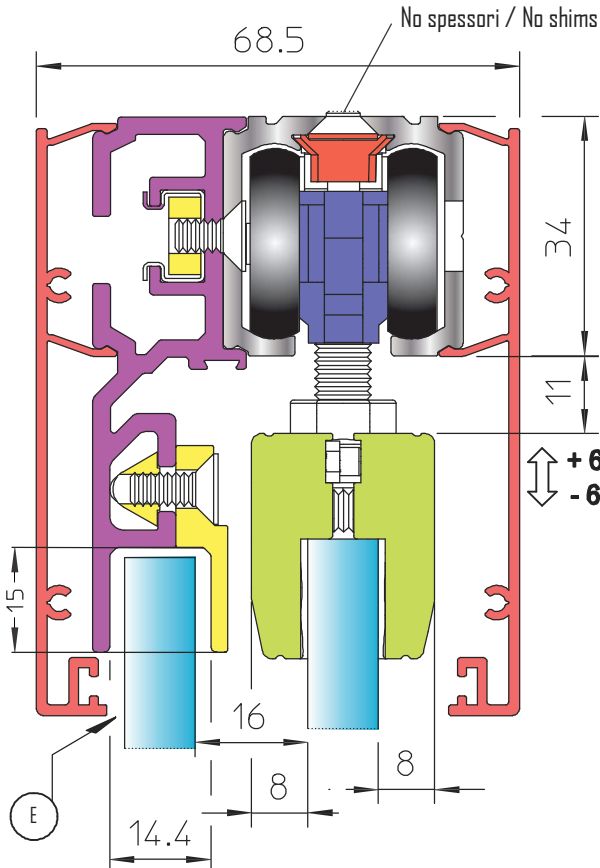

Il dado in gabbia A inserito nel profilo B e il tassello D inserito nel profilo B per fissare C.
 Inserimento frontale del vetro fisso E.
 The caged nut A inserted in the profile B and the block D inserted in the profile B to fix C.
 Front entry for fixed glass E.

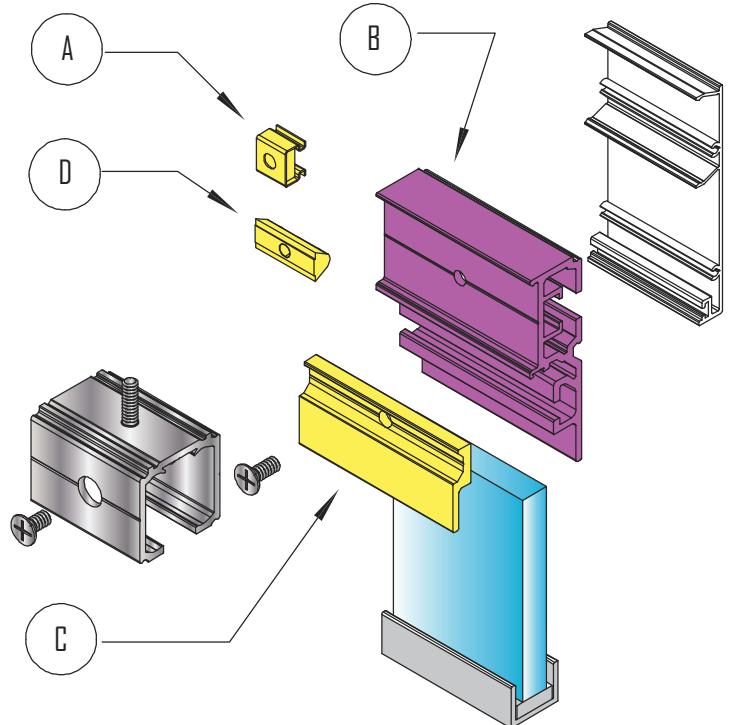

HP-G 1.0

45/65/90/130 kg

PATENT PENDING

4 SET PER AMMORTIZZARE IN ENTRAMBI I LATI ANTE DA 575 mm a 130 KG

4 KITS FOR SOFT-CLOSE IN CLOSING- AND OPENING-PHASE DOORS FROM 575 mm to 130 KG

4 BAUSÄTZE FÜR BEIDSEITIGE BREMS-DÄMPFUNG VON FLÜGELN AB 575 mm und bis 130 KG

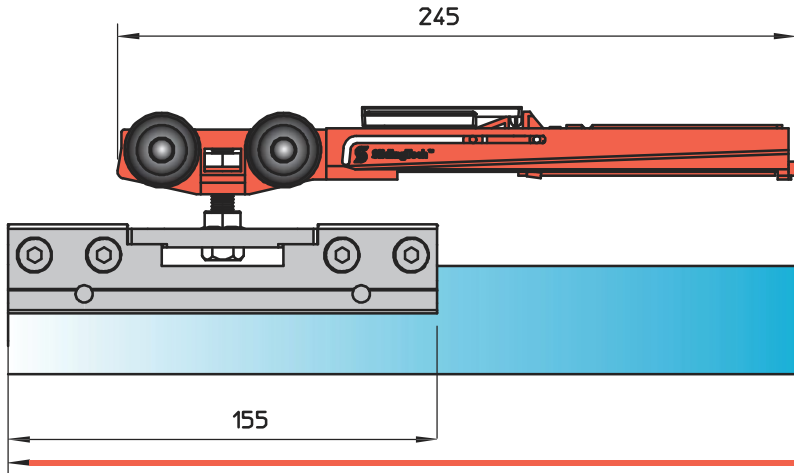

45 KG

AIR SYSTEM

STOP & SLIDE 45
Corsa frenante
Braking stroke 58 mm
Bremsweg

<< L min 575 >>

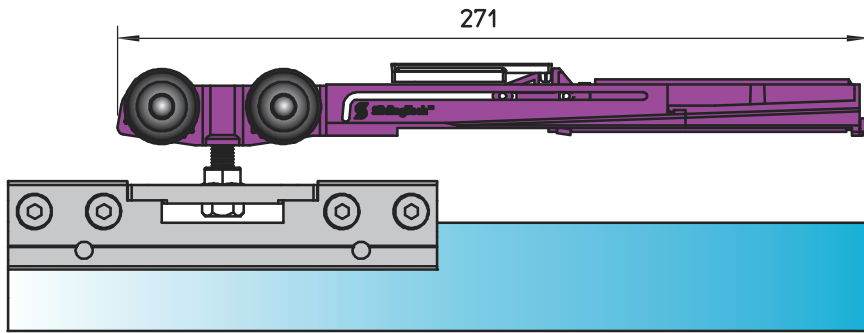

65 KG

OIL SYSTEM

STOP & SLIDE 65
Corsa frenante
Braking stroke 60 mm
Bremsweg

<< L min 625 >>

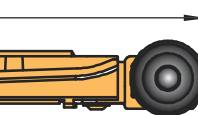
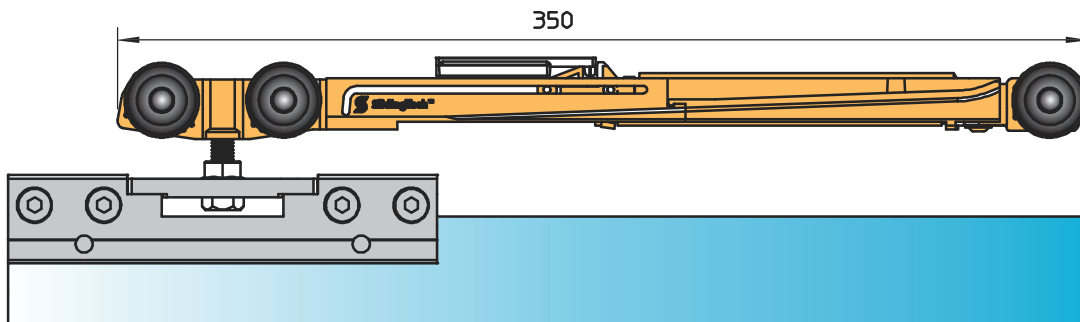

90 KG

OIL SYSTEM

STOP & SLIDE 90
Corsa frenante
Braking stroke 75 mm
Bremsweg

<< L min 780 >>

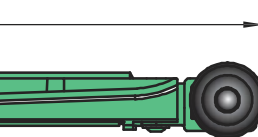
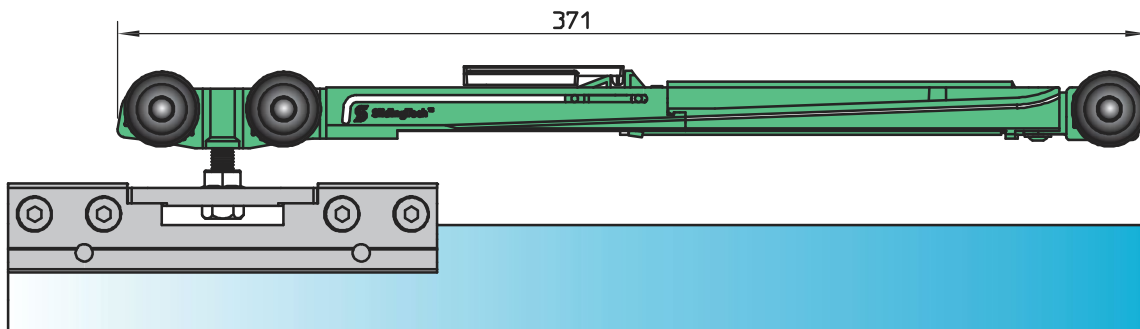

130 KG

OIL SYSTEM

STOP & SLIDE 130
Corsa frenante
Braking stroke 85 mm
Bremsweg

<< L min 825 >>